

Water reservoir

ARTICLE NO: 2194

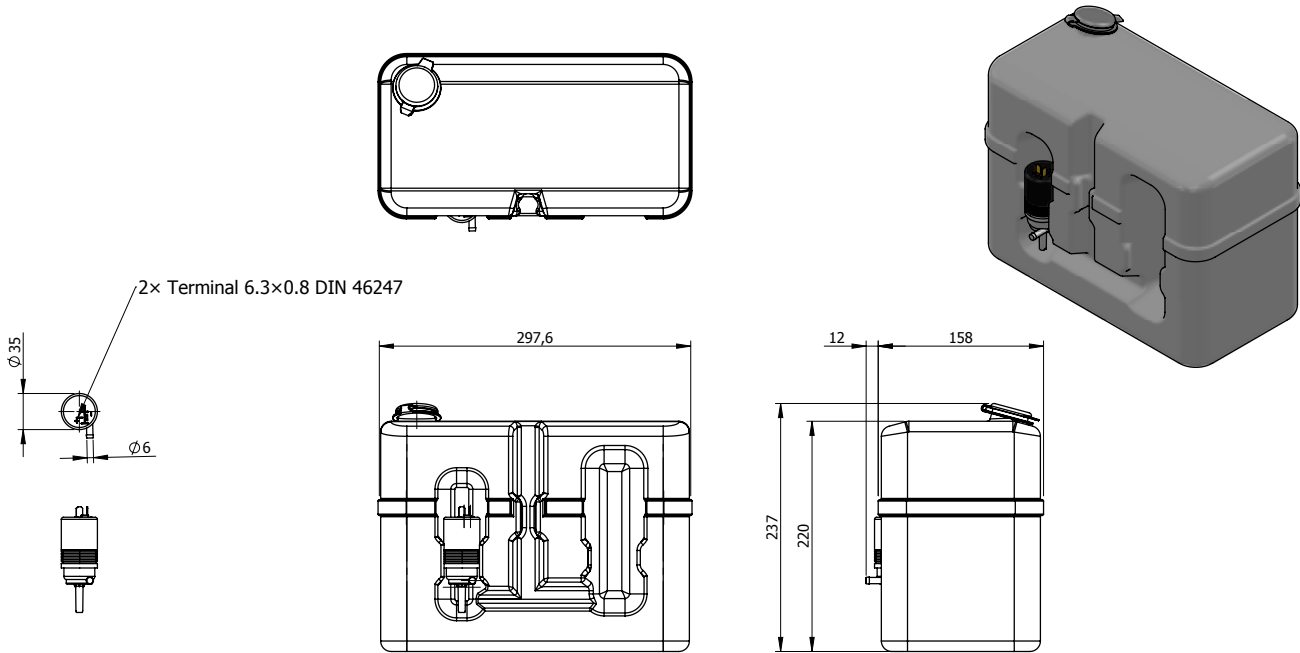

Information

Material: **Polyethylene (PE)**
 Temperature range*: **-40°C / 100°C**
 Combustion temperature: **± 350° C**
 Electrical insulation: **Excellent**
 Hardness (shore A): **65**
 Volume: **8 ltr.**

Pump (1pc)
 Voltage: **24V**
 Pressure: **2 bar**
 Capacity: **1 ltr/min.**

General resistance
 Mineral oils and greases: **Low**
 Animal/ vegetable oils and fats: **Good**
 Acid: **Excellent**
 Concentrated acids: **Good**

Solvents
 Aliphatic, gasoline, etc.: **Low**
 Aromats, toluene, benzene: **Low**
 Esters, ethers, alcohol: **Excellent**
 Chlorides; tetra, tri, etc.: **Moderate**
 Sunlight and ozone : **Good**

* At temperatures below 0°C, antifreeze has to be added to the wash water.